

# DIMENSION SHEET

## STREET ROD COUPE WITHOUT FENDERS

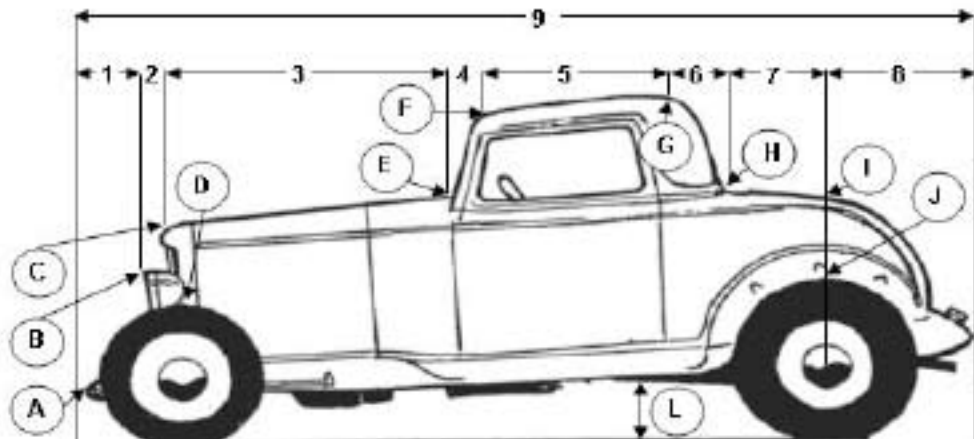

Lengths - Measured Horizontally

Heights - Measured from Ground

- # 1 Front of carto front of headlight \_\_\_\_\_
- # 2 Front of headlight to front of hood \_\_\_\_\_
- # 3 Front of hood to base of windshield \_\_\_\_\_
- # 4 Base of windshield to front of roof \_\_\_\_\_
- # 5 Front of roof to rear of roof \_\_\_\_\_
- # 6 Rear of roof to base of rear window \_\_\_\_\_
- # 7 Base of window to center of rear axle \_\_\_\_\_
- # 8 Center of rear axle to rear of car \_\_\_\_\_
- # 9 Overall length of car, front to rear \_\_\_\_\_

- HA Height at front of car \_\_\_\_\_
- HB Height at top of headlight \_\_\_\_\_
- HC Height at front of hood \_\_\_\_\_
- HD Height at top of front tire \_\_\_\_\_
- HE Height at base of windshield \_\_\_\_\_
- HF Height at front of roof \_\_\_\_\_
- HG Height at rear of roof \_\_\_\_\_
- HH Height at base of rear window \_\_\_\_\_
- HI Height of trunk at point "I" \_\_\_\_\_
- HJ Height at top of rear tire \_\_\_\_\_
- HK Height at rear of car \_\_\_\_\_
- HL Road clearance \_\_\_\_\_

If you have measured correctly, the sum of # 1  
through # 8 should equal # 9.

Widths, Measured Side to Side at Points Shown

- WA Width of car at front \_\_\_\_\_
- WB Width of car at top of headlights \_\_\_\_\_
- WC Width of car at front of hood \_\_\_\_\_
- WD Width of car at front tires \_\_\_\_\_
- WE Width of hood at windshield \_\_\_\_\_
- WF Width of roof at front \_\_\_\_\_

- WG Width of roof at rear \_\_\_\_\_
- WH Width at base of rear window \_\_\_\_\_
- WI Width of car across trunk at "I" \_\_\_\_\_
- WJ Width of car at rear tires \_\_\_\_\_
- WK Width of car at rear \_\_\_\_\_

### Vehicle Information

YEAR \_\_\_\_\_

MAKE \_\_\_\_\_

MODEL \_\_\_\_\_

Name \_\_\_\_\_ Daytime phone \_\_\_\_\_

Date of order \_\_\_\_\_

A photo of the vehicle will help us make the pattern.  
The photo will be returned if requested.