

DIMENSION SHEET

STREET ROD COUPE WITH FENDERS

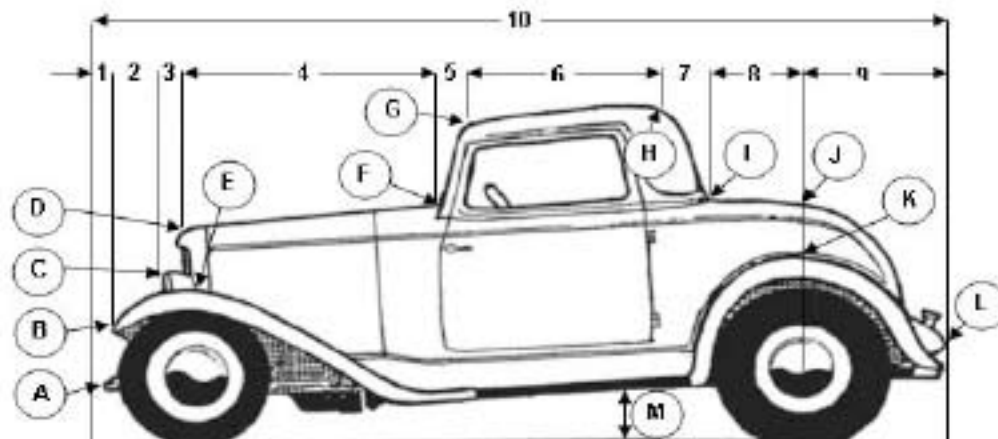

Lengths - Measured Horizontally

Heights - Measured from Ground

- # 1 Front of car to front of fender _____
- # 2 Front of fender to front of headlight _____
- # 3 Front of headlight to front of hood _____
- # 4 Front of hood to base of windshield _____
- # 5 Base of windshield to front of roof _____
- # 6 Front of roof to rear of roof _____
- # 7 Rear of roof to base of rear window _____
- # 8 Base of window to center of rear axle _____
- # 9 Center of rear axle to rear of car _____
- # 10 Overall length of car, front to rear _____

- HA Height at front of car _____
- HB Height at front of fender _____
- HC Height at top of headlight _____
- HD Height at front of hood _____
- HE Height at top of front fender _____
- HF Height at base of windshield _____
- HG Height at front of roof _____
- HH Height at rear of roof _____
- HI Height at base of rear window _____
- HJ Height of trunk at point "J" _____
- HK Height at top of rear fender _____
- HL Height at rear of car _____
- HM Road clearance _____

If you have measured correctly, the sum of # 1 through # 9 should equal # 10.

Widths, Measured Side to Side at Points Shown

- WA Width of car at front _____
- WB Width across front fenders _____
- WC Width of car at top of headlights _____
- WD Width of car at front of hood _____
- WE Width of car at top of fenders _____
- WF Width of hood at windshield _____

- WG Width of roof at front _____
- WH Width of roof at rear _____
- WI Width at base of rear window _____
- WJ Width of car across trunk at "J" _____
- WK Width of car at center of rear axle _____
- WL Width of car at rear _____

Vehicle Information

YEAR _____

MAKE _____

MODEL _____

Name _____ Daytime phone _____

Date of order _____

A photo of the vehicle will help us make the pattern. The photo will be returned if requested.